



ITRunner®

**AZIENDA CON SISTEMA
DI GESTIONE QUALITÀ
CERTIFICATO DA DNV
= ISO 9001 =**

b.o.b. Sistemi Idraulici S.p.A.

2 AXLES HOOKLIFT TRAILER ITR « 20.24 MT7 » MECHANIC SUSPENSIONS TELESCOPIC ARM

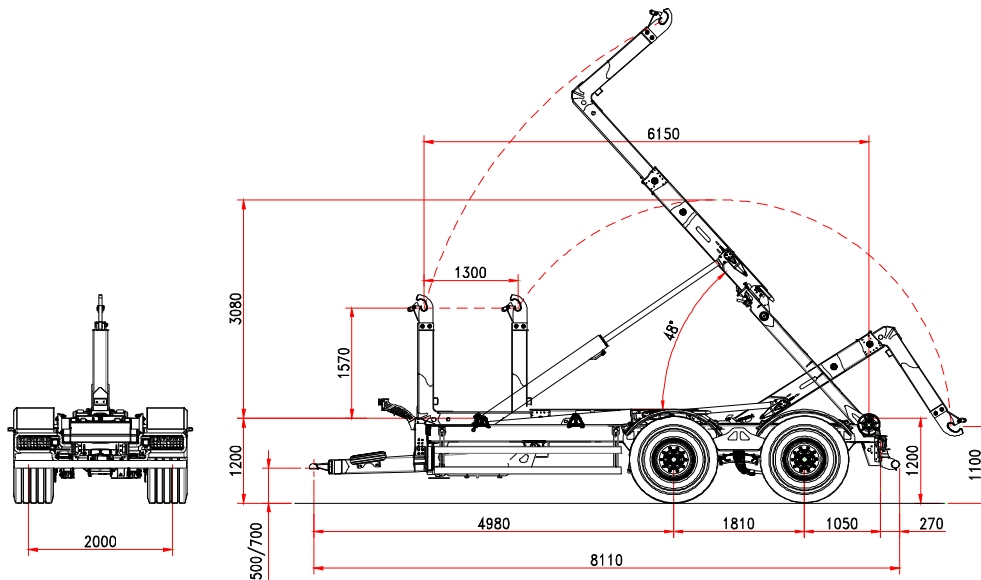

STANDARD FEATURES		TELESCOPIC ARM	
CHASSIS		run	1.300 mm
Frame section	250 x 100	Hook height	1.570
Drawbar	Silent block	Container locking	DIN forks
Suspension	24 t	Tipping angle	48°
Axles whb	1.810 mm	Hoist start cylinder	standard
Axles section (ADR type)	2x110	Tipping capacity (**)	22 ton
Axles	fixed+fixed	Lifting capacity (**)	20 ton
Track	2.000 mm		
Brake drum	406 x 120	OLEO-DYNAMIC SYSTEM	
Braking system	hydraulic	Tractor hydraulics:	2 controls double-acting
Towing eye	fixed	Oil requirements from the tractor	22 lt
Support foot	1 x hydraulic		
Wheel size	560/60 R22,5		
Chassis loading level	1.200 mm		
Front stab. cylinder 3 rd point	option		
WEIGHT AND DIMENSIONS			
G.T.W.	24 ton		
Dimensions min./max container	5.500/7.000 mm.		
Max speed	40 Km/h		
(*) Tare	6.300 kg		

Edit 07/2015

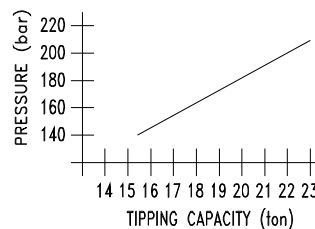
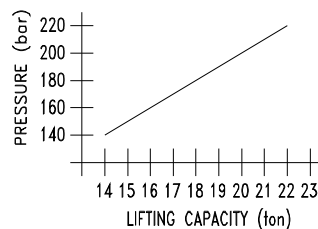

(*) The trailer tare is referred to the basic unit without options & accessories

(**) They may vary according to the type of tire and the pressure provided by the tractor

The technical details shown in this sheet are indicative and can be changed by the builder without prior notice.

B.O.B. Sistemi Idraulici S.p.A. – Regione Oltre Rea, 32 – 12060 Monchiero (CN) – Italia
P. I.V.A. 00496180043 - Tel.: +39 (0173) 780002/3 – Fax: +39 (0173) 780004
Internet: www.bobsna.com - e-mail: info@bobitalev.com